



MT21 SensingEdge

- Rolling Fire Doors
- Material Handling System

About the MT21...

The MT21 pressure sensitive electric edge is custom manufactured to your exact specifications for length, width, height and sensitivity. When touched lightly or at an angle, the MT21 will send an immediate electrical signal to your controls to stop, and/or reverse operations. It is completely flexible and will contour curved surfaces. In addition to being a sensing device, the MT21 also acts as a weatherstrip on doors to help save energy. Contact us with your specifications and we will design the best SensingEdge for your application.

Specifications

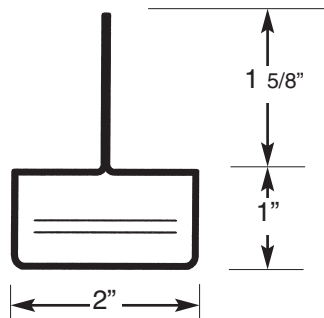

Color: Gray, yellow, black or white

Length: Per specification to the nearest 1/4"

Sensitivity: 3psi - standard

Lead Wire: 24" SJTO 18 gauge - standard

Wire Outlet Location: specify right hand, left hand or end

Electrical Requirements: 24 volts, 1/2 amp
AC or DC power

Electrical Diagram: 2-wire, N.O. configuration

Electrical Contact Element: Alumaglas®

Cover: Heavy duty reinforced PVC

Temperature Range: -30°F to +155°F



Options

- 4 wire N.O. configuration
- Pneumatic (MTP21) Air-Wave (MTAW21)
- 4-wire control panel (MFSC-100)
- Yellow/Black striped cover material
- 4-wire intrinsically-safe control panel (FSIS-25-4)
- XR-5 chemically resistant cover for protection against:

kerosene	50% phosphoric acid
diesel fuel	50% hydrochloric acid
JP-4 jet fuel	50% acetic acid
salt water	SAE-30 oil

Installation

To install remove edge from shipping container and lay out flat and straight. Close air valve. Position edge in desired location and attach with screws through mounting flange at ends and center. Continue to attach edge by securing mounting flange with screws placed 24" apart. Do not place screws below seal line. For detailed installation & wiring instructions, contact MillerEdge, Inc.

Care of the MT21

Minimal care is required for MT style SensingEdges since they are manufactured with only the most durable materials and the highest quality control standards. However, SensingEdges should be examined regularly for cuts or punctures which could damage internal components. Also check wiring to be sure connections are secure. When properly maintained, the MT21 offers years of trouble-free operation.

SensingEdge



Warranty

We will replace within one year of shipment from our factory, any SensingEdge subject to normal use which is found to have defective materials or workmanship, as determined solely by our factory representative. Replacements will be shipped to you freight collect. This warranty is void where evidence of misuse or abuse is present.

Notes